

Архангельск (8182)63-90-72 Астана (7172)727-132 Астрахань (8512)99-46-04 Барнаул (3852)73-04-60 Белгород (4722)40-23-64 Брянск (4832)59-03-52 Владивосток (423)249-28-31 Волгоград (844)278-03-48  
 Вологда (8172)26-41-59 Воронеж (473)204-51-73 Екатеринбург (343)384-55-89 Иваново (4932)77-34-06 Ижевск (3412)26-03-58 Казань (843)206-01-48 Калининград (4012)72-03-81 Калуга (4842)92-23-67  
 Кемерово (3842)65-04-62 Киров (8332)68-02-04 Краснодар (861)203-40-90 Красноярск (391)204-63-61 Курск (4712)77-13-04 Липецк (4742)52-20-81 Магнитогорск (3519)55-03-13 Москва (495)268-04-70  
 Мурманск (8152)59-64-93 Набережные Челны (8552)20-53-41 Нижний Новгород (831)429-08-12 Новокузнецк (3843)20-46-81 Новосибирск (383)227-86-73 Омск (3812)21-46-40 Орел (4862)44-53-42  
 Оренбург (3532)37-68-04 Пенза (8412)22-31-16 Пермь (342)205-81-47 Ростов-на-Дону (863)308-18-15 Рязань (4912)46-61-64 Самара (846)206-03-16 Санкт-Петербург (812)309-46-40 Саратов (845)249-38-78  
 Севастополь (8692)22-31-93 Симферополь (3652)67-13-56 Смоленск (4812)29-41-54 Сочи (862)225-72-31 Ставрополь (8652)20-65-13 Сургут (3462)77-98-35 Тверь (4822)63-31-35 Томск (3822)98-41-53  
 Тула (4872)74-02-29 Тюмень (3452)66-21-18 Ульяновск (8422)24-23-59 Уфа (347)229-48-12 Хабаровск (4212)92-98-04 Челябинск (351)202-03-61 Череповец (8202)49-02-64 Ярославль (4852)69-52-93

Единый адрес: [ath@nt-rt.ru](mailto:ath@nt-rt.ru) | <http://albright.nt-rt.ru>

The SW800 is designed for use in telecommunication and power distribution applications where an uninterrupted load is switched. These contactors are primarily for use with Direct Current loads but can also be used with Alternating Currents.

- Uninterrupted current - no or infrequent load switching requirements (maintains a lower contact resistance).

Application	Uninterrupted
Thermal Current Rating ( $I_{th}$ )	800A
Intermittent Current Rating:	
30% Duty	1460A
40% Duty	1265A
50% Duty	1130A
60% Duty	1035A
70% Duty	955A
Rated Fault Current Breaking Capacity ( $I_{cn}$ ) Resistive Load: (in accordance with UL508*)	
SW800	1200A at 60V D.C.
Maximum Recommended Contact Voltages ( $U_{\phi}$ ):	
SW800	60V D.C.
Typical Voltage Drop per pole across New Contacts at 100A	<50mV
Mechanical M.T.B.F	>1 x 10 <sup>6</sup>
Coil Voltage Available ( $U_s$ ) (Rectifier board required for A.C.)	From 6 to 240V A.C./D.C.
Coil Power Dissipation:	
Highly Intermittent Rated Types	60 - 90 Watts
Intermittently Rated Types	40 - 60 Watts
Prolonged Rated Types	35 - 40 Watts
Continuously Rated Types	25 - 35 Watts
Maximum Pull-In Voltage (Coil at 20° C) Guideline:	
Highly Intermittent Rated types (Max 25% Duty Cycle)	60% $U_s$
Intermittently Rated types (Max 70% Duty Cycle)	60% $U_s$
Prolonged Operation (Max 90% Duty Cycle)	60% $U_s$
Continuously Rated Types (100% Duty Cycle)	66% $U_s$
Drop-Out Voltage Range	10 - 30% $U_s$
Typical Pull-In Time	40ms
Typical Drop-Out Time (N/O Contacts to Open):	
Without Suppression	10ms
With Diode Suppression	100ms
With Diode and Resistor (Subject to resistance value)	30ms
Typical Contact Bounce Period	< 5ms
Operating Ambient Temperature	-40°C to +60°C
Guideline Contactor Weight:	
SW800	1600 gms
With Auxiliary	+ 20 gms

Auxiliary Details	
Auxiliary Thermal Current Rating	5A
Auxiliary Contact Switching Capabilities (Resistive Load):	
SW800A	SW800C
5A at 24V D.C.	
2A at 48V D.C.	
0.5A at 240V D.C.	

Advised Connection Sizes for Maximum Continuous Current	
Copper busbar	412mm <sup>2</sup> [0.64inch <sup>2</sup> ]
Cable	Rated suitable for Application

Key: ▲ = Uninterrupted

Note: Where applicable values shown are at 20° C

\* Please check our web site for product UL status

The SW800 features double breaking main contacts with silver alloy tips which are weld resistant, hard wearing and have excellent conductivity. Silver plating on the main contacts is standard for the SW800, however, optionally it can be excluded from the specification. This compact contactor can be busbar mounted vertically or horizontally, but if mounted vertically, the coil should be at the bottom. If the coil is required at the top, we can adjust the contactor to compensate for this. Optional extras include Auxiliary switches, brackets, coil finishes and magnetic latching which allows the contactor to remain closed while consuming no coil power.

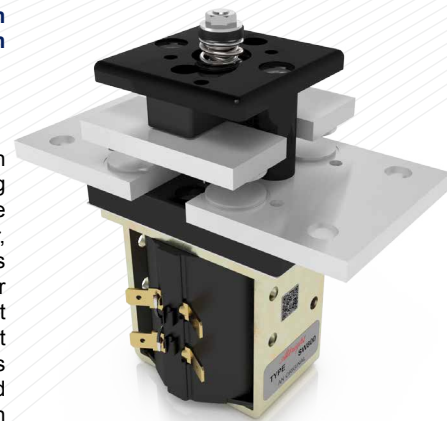

SW800

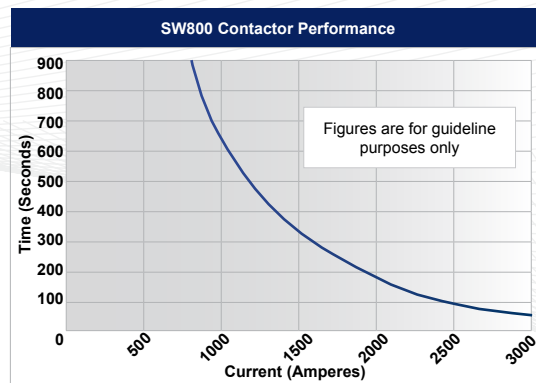
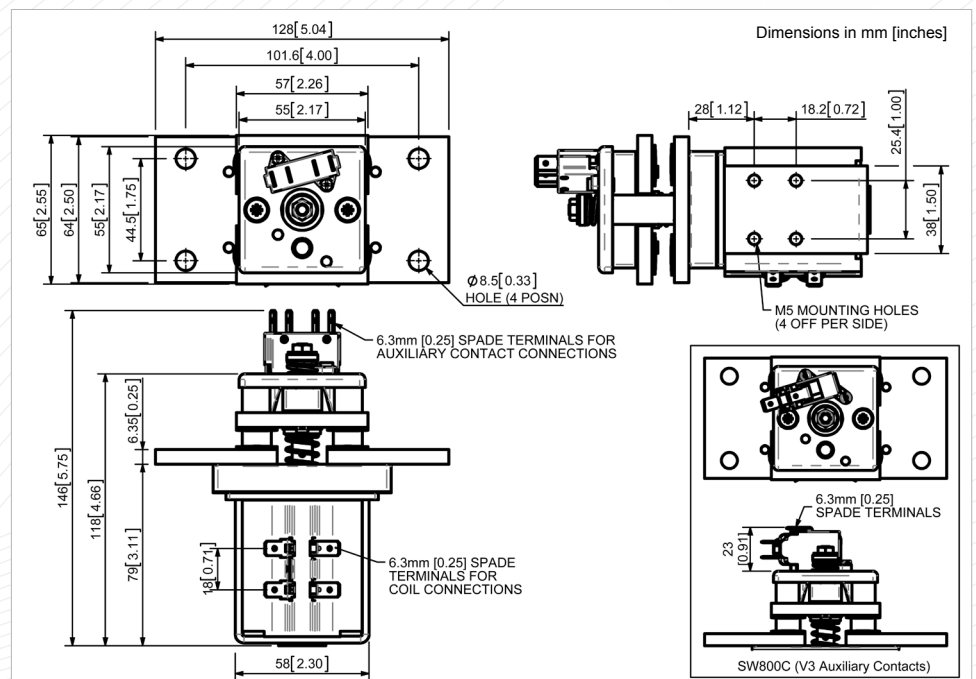

Contact Performance Key:

— Uninterrupted Current

Connection Diagram

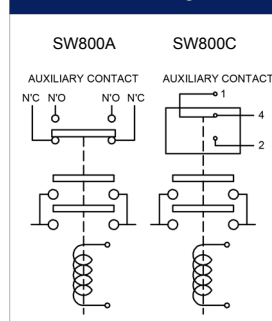

SW800 Available Options		
General		Suffix
Auxiliary Contacts	○	A
Auxiliary Contacts - V3	○	C
Magnetic Blowouts†	X	
Magnetic Blowouts - High Powered†	X	
Armature Cap	X	
Mounting Brackets (see Busbar Series Catalogue)	○	
Magnetic Latching† (Not fail safe)	○	M
Closed Contact Housing	X	
Environmentally Protected IP66	X	
EE Type (Steel Shroud)	X	
Contacts		
Large Tips	X	
Textured Tips	X	
Silver Plating (fitted as standard)	○	
Coil		
AC Rectifier Board (Fitted)	○	
Coil Suppression†	○	
Flying Leads	○	F
Manual Override Operation	○	
M4 Stud Terminals	X	
M5 Terminal Board	X	
Vacuum Impregnation	○	
Key: Optional ○ Standard ● Not Available X		
† Connections become polarity sensitive		