

Архангельск (8182)63-90-72 Астана (7172)727-132 Астрахань (8512)99-46-04 Барнаул (3852)73-04-60 Белгород (4722)40-23-64 Брянск (4832)59-03-52 Владивосток (423)249-28-31 Волгоград (844)278-03-48 Вологда (8172)26-41-59 Воронеж (473)204-51-73 Екатеринбург (343)384-55-89 Иваново (4932)77-34-06 Ижевск (3412)26-03-58 Казань (843)206-01-48 Калининград (4012)72-03-81 Калуга (4842)92-23-67 Кемерово (3842)65-04-62 Киров (8332)68-02-04 Краснодар (861)203-40-90 Красноярск (391)204-63-61 Курск (4712)77-13-04 Липецк (4742)52-20-81 Магнитогорск (3519)55-03-13 Москва (495)268-04-70 Мурманск (8152)59-64-93 Набережные Челны (8552)20-53-41 Нижний Новгород (831)429-08-12 Новокузнецк (3843)20-46-81 Новосибирск (383)227-86-73 Омск (3812)21-46-40 Орел (4862)44-53-42 Оренбург (3532)37-68-04 Пенза (8412)22-31-16 Пермь (342)205-81-47 Ростов-на-Дону (863)308-18-15 Рязань (4912)46-61-64 Самара (846)206-03-16 Санкт-Петербург (812)309-46-40 Саратов (845)249-38-78 Севастополь (8692)22-31-93 Симферополь (3652)67-13-56 Смоленск (4812)29-41-54 Сочи (862)225-72-31 Ставрополь (8652)20-65-13 Сургут (3462)77-98-35 Тверь (4822)63-31-35 Томск (3822)98-41-53 Тула (4872)74-02-29 Тюмень (3452)66-21-18 Ульяновск (8422)24-23-59 Уфа (347)229-48-12 Хабаровск (4212)92-98-04 Челябинск (351)202-03-61 Череповец (8202)49-02-64 Ярославль (4852)69-52-93

Единый адрес: [ath@nt-rt.ru](mailto:ath@nt-rt.ru) | <http://albright.nt-rt.ru>

Application	Interrupted	Uninterrupted
Thermal Current Rating (I <sub>th</sub> )	100A	125A
Intermittent Current Rating:		
30% Duty	185A	230A
40% Duty	160A	200A
50% Duty	140A	175A
60% Duty	130A	160A
70% Duty	120A	150A
Rated Fault Current Breaking Capacity (I <sub>cn</sub> ) 5ms Time Constant: (in accordance with UL583*)		
SW80	800A at 48V	
SW80B	800A at 80V	
Rated Fault Current Breaking Capacity (I <sub>cn</sub> ) Resistive Load: (in accordance with UL508*)		
SW80	190A at 60V D.C.	
SW80B	190A at 96V D.C.	
Maximum Recommended Contact Voltages (U <sub>0</sub> ):		
SW80	48V D.C.	60V D.C.
SW80B		96V D.C.
Typical Voltage Drop per pole across New Contacts at 100A	40mV	
Mechanical M.T.B.F	>5 x 10 <sup>6</sup>	
Coil Voltage Available (U <sub>s</sub> ) (Rectifier board required for A.C.)	From 6 to 240V D.C.	
Coil Power Dissipation:		
Highly Intermittent Rated Types	20 - 30 Watts	
Intermittently Rated types	15 - 20 Watts	
Prolonged Rated Types	13 - 15 Watts	
Continuously Rated Types	7 - 13 Watts	
Maximum Pull-In Voltage (Coil at 20° C) Guideline:		
Highly Intermittent Rated types (Max 25% Duty Cycle)	60% U <sub>s</sub>	
Intermittently Rated types (Max 70% Duty Cycle)	60% U <sub>s</sub>	
Prolonged Operation (Max 90% Duty Cycle)	60% U <sub>s</sub>	
Continuously Rated Types (100% Duty Cycle)	66% U <sub>s</sub>	
Drop-Out Voltage Range	10 - 25% U <sub>s</sub>	
Typical Pull-In Time	20ms	
Typical Drop-Out Time (N/O Contacts to Open):		
Without Suppression	5ms	
With Diode Suppression	50ms	
With Diode and Resistor (Subject to resistance value)	8 - 20ms	
Typical Contact Bounce Period	3ms	
Operating Ambient Temperature	- 40°C to + 60°C	
Guideline Contactor Weight:		
SW80	350 gms	
With Auxiliary	+ 20 gms	
With Blowouts	+ 50 gms	
Auxiliary Thermal Current Rating		
	5A	
Auxiliary Contact Switching Capabilities (Resistive Load):		
	SW80A	SW80C
	5A at 24V D.C.	
	2A at 48V D.C.	
	0.5A at 240V D.C.	
Advised Connection Sizes for Maximum Continuous Current		
Copper busbar	80mm <sup>2</sup> [0.124inch <sup>2</sup> ]	
Cable	Rated suitable for Application	
Key: <span style="color:red">■</span> = Interrupted <span style="color:blue">■</span> = Uninterrupted		
Note: Where applicable values shown are at 20° C		
* Please check our web site for product UL status		

The SW80 has been designed for direct current loads, including motors as used on electric vehicles such as industrial trucks, and telecom and power distribution applications. Developed for both interrupted and uninterrupted loads, the SW80 is suitable for switching Resistive, Capacitive and Inductive loads.

- **Interrupted current** - opening and closing on load with frequent switching (results in increased contact resistance).
- **Uninterrupted current** - no or infrequent load switching requirements (maintains a lower contact resistance).

The SW80 features single pole double breaking main contact contacts with silver alloy tips, which are weld resistant, hard wearing and have excellent conductivity. The SW80 has M8 stud main terminals and 6.3mm spade coil connections. Mounting is via M4 tapped holes or mounting brackets, either supplied fitted, or as separate items. Mounting can be horizontal or vertical, when vertical the M8 contact studs should point upwards. If the requirement is for downwards orientation we can adjust the contactor to compensate for this.

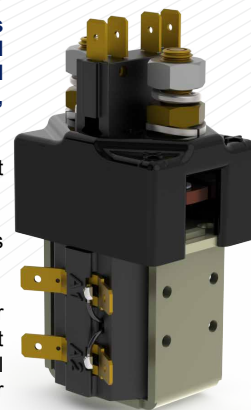

SW80A

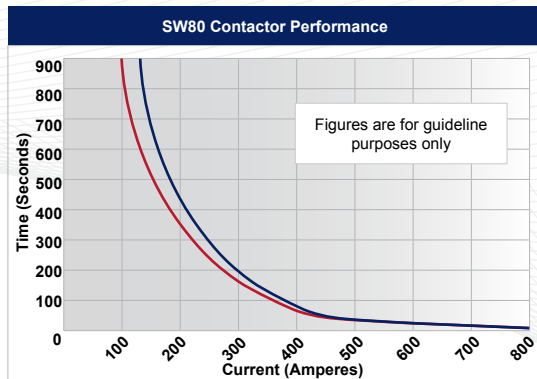
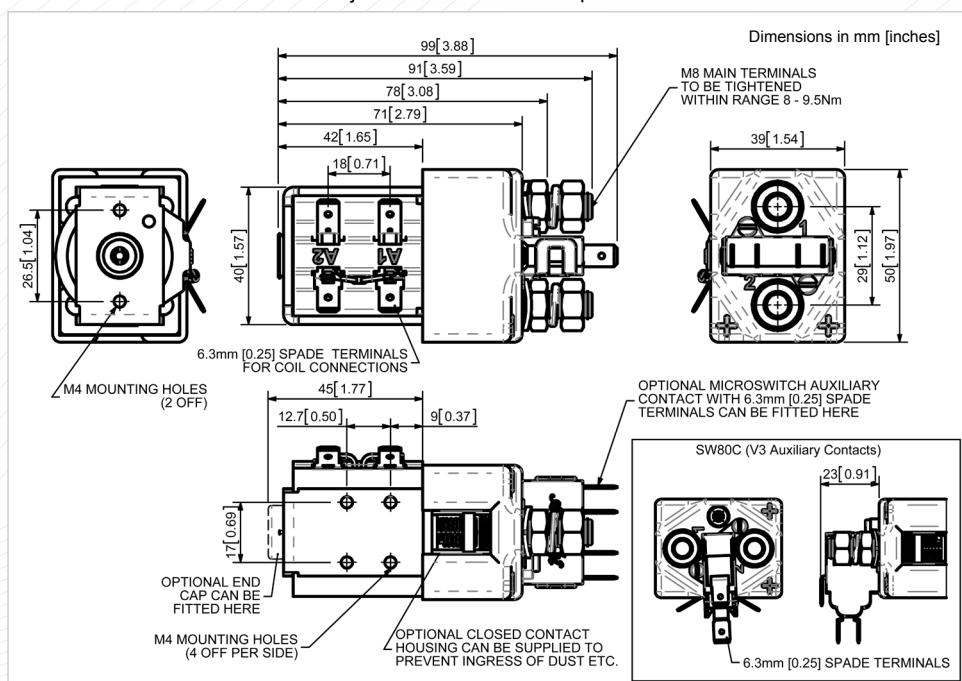

Contact Performance Key:

- Interrupted Current
- Uninterrupted Current

Connection Diagram

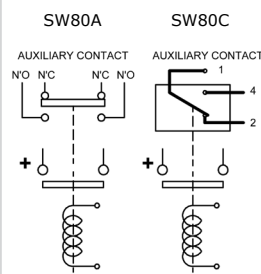

SW80 Available Options		
General		Suffix
Auxiliary Contacts	<input type="radio"/>	A
Auxiliary Contacts - V3	<input type="radio"/>	C
Magnetic Blowouts†	<input type="radio"/>	B
Magnetic Blowouts - High Powered†	<input type="radio"/>	B
Armature Cap	<input type="radio"/>	
Mounting Brackets (See Stud Series Catalogue)	<input type="radio"/>	
Magnetic Latching† (Not fail safe)	<input type="radio"/>	M
Closed Contact Housing†	<input type="radio"/>	
Environmentally Protected IP66 (see SW80P Catalogue sheet)	<input type="radio"/>	P
EE Type (Steel Shroud)	<input type="radio"/>	EE
Contacts		
Large Tips	<input type="radio"/>	L
Textured Tips	<input type="radio"/>	T
Silver Plating	<input checked="" type="checkbox"/>	X
Coil		
AC Rectifier Board (Fitted)	<input type="radio"/>	
Coil Suppression†	<input type="radio"/>	
Flying Leads	<input type="radio"/>	F
Manual Override Operation	<input type="radio"/>	
M4 Stud Terminals	<input checked="" type="checkbox"/>	X
M5 Terminal Board	<input type="radio"/>	
Vacuum Impregnation	<input type="radio"/>	
Key: Optional <input type="radio"/> Standard <input checked="" type="checkbox"/> Not Available X		
† Connections become polarity sensitive		
‡ Open Housing Available		