

Архангельск (8182)63-90-72 Астана (7172)727-132 Астрахань (8512)99-46-04 Барнаул (3852)73-04-60 Белгород (4722)40-23-64 Брянск (4832)59-03-52 Владивосток (423)249-28-31 Волгоград (844)278-03-48
 Вологда (8172)26-41-59 Воронеж (473)204-51-73 Екатеринбург (343)384-55-89 Иваново (4932)77-34-06 Ижевск (3412)26-03-58 Казань (843)206-01-48 Калининград (4012)72-03-81 Калуга (4842)92-23-67
 Кемерово (3842)65-04-62 Киров (8332)68-02-04 Краснодар (861)203-40-90 Красноярск (391)204-63-61 Курск (4712)77-13-04 Липецк (4742)52-20-81 Магнитогорск (3519)55-03-13 Москва (495)268-04-70
 Мурманск (8152)59-64-93 Набережные Челны (8552)20-53-41 Нижний Новгород (831)429-08-12 Новокузнецк (3843)227-86-73 Омск (3812)21-46-40 Орел (4862)44-53-42
 Оренбург (3532)37-68-04 Пенза (8412)22-31-16 Пермь (342)205-81-47 Ростов-на-Дону (863)308-18-15 Рязань (4912)46-61-64 Самара (846)206-03-16 Санкт-Петербург (812)309-46-40 Саратов (845)249-38-78
 Севастополь (8692)22-31-93 Симферополь (3652)67-13-56 Смоленск (4812)29-41-54 Сочи (862)225-72-31 Ставрополь (8652)20-65-13 Сургут (3462)77-98-35 Тверь (4822)63-31-35 Томск (3822)98-41-53
 Тула (4872)74-02-29 Тюмень (3452)66-21-18 Ульяновск (8422)24-23-59 Уфа (347)229-48-12 Хабаровск (4212)92-98-04 Челябинск (351)202-03-61 Череповец (8202)49-02-64 Ярославль (4852)69-52-93

Единый адрес: ath@nt-rt.ru | <http://albright-nt-rt.ru>

Application	Interrupted	Uninterrupted
Thermal Current Rating (I _{th})	150A	200A
Intermittent Current Rating:		
30% Duty	275A	365A
40% Duty	235A	315A
50% Duty	210A	280A
60% Duty	190A	260A
70% Duty	180A	240A
Rated Fault Current Breaking Capacity (I _{cn}) 5ms Time Constant: (in accordance with UL583*)		
SU80	800A at 48V D.C.	
SU80B	800A at 80V D.C.	
Rated Fault Current Breaking Capacity (I _{cn}) Resistive Load: (in accordance with UL583*)		
SU80	300A at 60V D.C.	
SU80B	300A at 96V D.C.	
Maximum Recommended Contact Voltages (U _e):		
SU80	48V D.C.	60V D.C.
SU80B		96V D.C.
Typical Voltage Drop per pole across New Contacts at 100A	<40mV	
Mechanical M.T.B.F	>3 x 10 ⁶	
Coil Voltage Available (U _s) (Rectifier board required for A.C.)	From 6 to 240V A.C./D.C.	
Coil Power Dissipation:		
Highly Intermittent Rated Types	20 - 30 Watts	
Intermittently Rated types	15 - 20 Watts	
Prolonged Rated Types	13 - 15 Watts	
Continuously Rated Types	7 - 13 Watts	
Maximum Pull-In Voltage (Coil at 20° C) Guideline:		
Highly Intermittent Rated types (Max 25% Duty Cycle)	60% U _s	
Intermittently Rated types (Max 70% Duty Cycle)	60% U _s	
Prolonged Operation (Max 90% Duty Cycle)	60% U _s	
Continuously Rated Types (100% Duty Cycle)	66% U _s	
Drop-Out Voltage Range	10 - 25% U _s	
Typical Pull-In Time	20ms	
Typical Drop-Out Time (N/O Contacts to Open):		
Without Suppression	5ms	
With Diode Suppression	50ms	
With Diode and Resistor (Subject to resistance value)	8 - 20ms	
Typical Contact Bounce Period	3ms	
Operating Ambient Temperature	- 40° C to + 60° C	
Guideline Contactor Weight:		
SU80	350 gms	
With Auxiliary	+ 20 gms	
With Blowouts	+ 50 gms	
Auxiliary Details		
Auxiliary Thermal Current Rating	5A	
Auxiliary Contact Switching Capacities (Resistive Load):		
	SU80A	SU80C
	5A at 24V D.C.	
	2A at 48V D.C.	
	0.5A at 240V D.C.	
Advised Connection Sizes for Maximum Continuous Current		
Copper busbar	97mm ² [0.15inch ²]	129mm ² [0.20inch ²]
Cable	Rated suitable for Application	
Key:	■ = Interrupted ■ = Uninterrupted	
Note:	Where applicable values shown are at 20° C	
*	Please check our web site for product UL status	

The SU80 is an up-rated version of the SW80 Contactor designed for Interrupted and Uninterrupted loads. It is suitable for switching Resistive, Capacitive and Inductive loads. Typical applications include, but are not limited to, electric motors, hydraulic power packs, winches, speed controllers, UPS and Power Distribution Systems.

- Interrupted current - opening and closing on load with frequent switching (results in increased contact resistance).
- Uninterrupted current - no or infrequent load switching requirements (maintains a lower contact resistance).

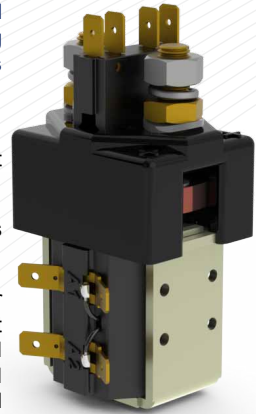

SU80A

The SU80 features single pole double breaking main contacts with silver alloy tips, which are weld resistant, hard wearing and have excellent conductivity. Economical in price they compare favourably with sealed automotive style solenoid switches which cannot be serviced or inspected for contact wear. Mounting can be vertical or horizontal, when vertical the M8 contact studs should point upwards. If the requirement is for downwards orientation we can adjust the contactor to compensate for this.

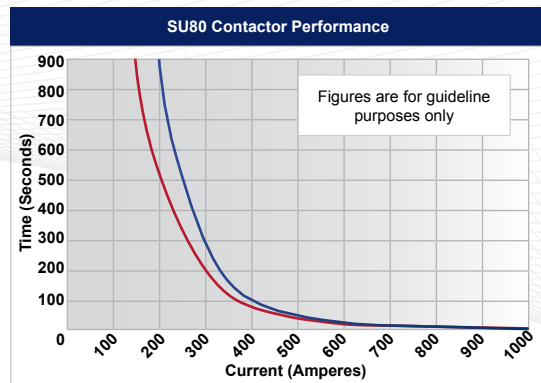
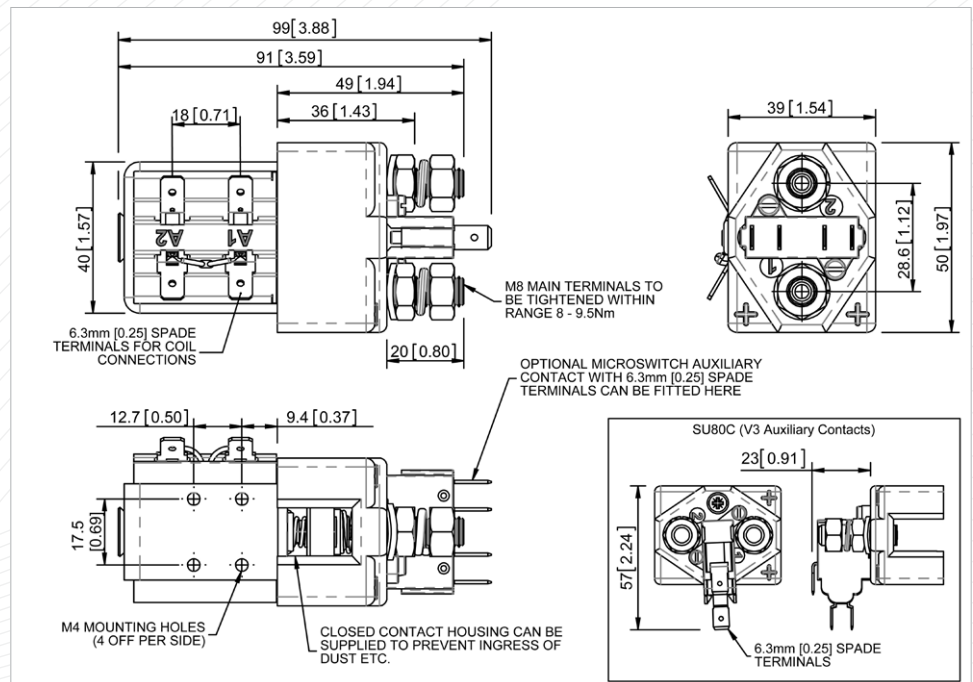

Contact Performance Key:
— Interrupted Current
— Uninterrupted Current

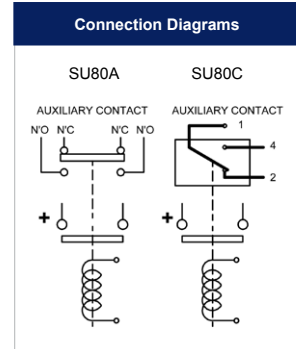

SU80 Available Options		
General		Suffix
Auxiliary Contacts	<input type="radio"/>	A
Auxiliary Contacts - V3	<input type="radio"/>	C
Magnetic Blowouts†	<input type="radio"/>	B
Magnetic Blowouts - High Powered†	<input type="radio"/>	B
Armature Cap	<input type="radio"/>	
Mounting Brackets (see SU Series Catalogue)	<input type="radio"/>	
Magnetic Latching† (Not fail safe)	<input type="radio"/>	M
Closed Contact Housing	<input type="radio"/>	
Environmentally Protected IP66	<input type="radio"/>	P
EE Type (Steel Shroud)	<input type="radio"/>	EE
Contacts		
Large Tips	<input type="radio"/>	L
Textured Tips	<input type="radio"/>	T
Silver Plating	<input checked="" type="checkbox"/>	X
Coil		
AC Rectifier Board (Fitted)	<input type="radio"/>	
Coil Suppression†	<input type="radio"/>	
Flying Leads	<input type="radio"/>	F
Manual Override Operation	<input type="radio"/>	
M4 Stud Terminals	<input checked="" type="checkbox"/>	X
M5 Terminal Board	<input type="radio"/>	
Vacuum Impregnation	<input type="radio"/>	
Key:	<input type="radio"/> Optional	<input type="radio"/> Standard <input checked="" type="checkbox"/> Not Available <input checked="" type="checkbox"/> X
† Connections become polarity sensitive		