

Архангельск (8182)63-90-72 Астана (7172)727-132 Астрахань (8512)99-46-04 Барнаул (3852)73-04-60 Белгород (4722)40-23-64 Брянск (4832)59-03-52 Владивосток (423)249-28-31 Волгоград (844)278-03-48
 Вологда (8172)26-41-59 Воронеж (473)204-51-73 Екатеринбург (343)384-55-89 Иваново (4932)77-34-06 Ижевск (3412)26-03-58 Казань (843)206-01-48 Калининград (4012)72-03-81 Калуга (4842)92-23-67
 Кемерово (3842)65-04-62 Киров (8332)68-02-04 Краснодар (861)203-40-90 Красноярск (391)204-63-61 Курск (4712)77-13-04 Липецк (4742)52-20-81 Магнитогорск (3519)55-03-13 Москва (495)268-04-70
 Мурманск (8152)59-64-93 Набережные Челны (8552)20-53-41 Нижний Новгород (831)429-08-12 Новокузнецк (3843)20-46-81 Новосибирск (383)227-86-73 Омск (3812)21-46-40 Орел (4862)44-53-42
 Оренбург (3532)37-68-04 Пенза (8412)22-31-16 Пермь (342)205-81-47 Ростов-на-Дону (863)308-18-15 Рязань (4912)46-61-64 Самара (846)206-03-16 Санкт-Петербург (812)309-46-40 Саратов (845)249-38-78
 Севастополь (8692)22-31-93 Симферополь (3652)67-13-56 Смоленск (4812)29-41-54 Сочи (862)225-72-31 Ставрополь (8652)20-65-13 Сургут (3462)77-98-35 Тверь (4822)63-31-35 Томск (3822)98-41-53
 Тула (4872)74-02-29 Тюмень (3452)66-21-18 Ульяновск (8422)24-23-59 Уфа (347)229-48-12 Хабаровск (4212)92-98-04 Челябинск (351)202-03-61 Череповец (8202)49-02-64 Ярославль (4852)69-52-93

Единый адрес: ath@nt-rt.ru | <http://albright.nt-rt.ru>

Application	Uninterrupted
Thermal Current Rating (I _{th})	300A
Intermittent Current Rating:	
30% Duty	545A
40% Duty	475A
50% Duty	425A
60% Duty	385A
70% Duty	360A
Rated Fault Current Breaking Capacity (I _{cn}) 5ms Time Constant: (in accordance with UL583 [®])	
SD300	1000A at 48V D.C.
SD300B	1000A at 80V D.C.
Maximum Recommended Contact Voltages (U _c):	
SD300	48V D.C.
SD300B	96V D.C.
Typical Voltage Drop per pole across New Contacts at 100A	<30mV
Mechanical M.T.B.F	>10 x 10 ³
Electrical M.T.B.F	>3 x 10 ⁶
Coil Voltage Available (U _s)	From 6 to 240V A.C./D.C.**
Coil Power Dissipation:	
Highly Intermittent Rated Types	40 - 50 Watts
Intermittently Rated types	30 - 40 Watts
Prolonged Rated Types	15 - 30 Watts
Continuously Rated Types	10 - 15 Watts
Maximum Pull-In Voltage (Coil at 20° C) Guideline:	
Highly Intermittent Rated types (Max 25% Duty Cycle)	60% U _s
Intermittently Rated types (Max 70% Duty Cycle)	60% U _s
Prolonged Operation (Max 90% Duty Cycle)	60% U _s
Continuously Rated Types (100% Duty Cycle)	66% U _s
Drop-Out Voltage Range	10 - 25%
Typical Pull-In Time	30ms
Typical Drop-Out Time (N/O Contacts to Open):	
Without Suppression	8ms
With Diode Suppression	60ms
With Diode and Resistor	25ms
Typical Contact Bounce Period	3ms
Operating Ambient Temperature	- 40° C to + 60° C
Guideline Contactor Weight:	
SD300	780 gms
With Auxiliary	+ 20 gms
With Blowouts	+ 50 gms
Auxiliary Details	
Auxiliary Thermal Current Rating	5A
Auxiliary Contact Switching Capabilities (Resistive Load):	
	5A at 24V D.C.
	2A at 48V D.C.
	0.5A at 240V D.C.
Advised Connection Sizes for Maximum Continuous Current	
Copper busbar	195mm ² [0.3inch ²]
Cable	Rated suitable for Application
Key: ▲ = Uninterrupted	
Note: Where applicable values shown are at 20° C	
* Please check our web site for product UL status	
** A.C. Rectifier available on Fuseholder type only	

The SD300 has been designed to provide a rapid means of disconnecting batteries or other power supplies in the event of serious electrical faults.

The SD300 combines the dual function of a manual disconnect and coil operated line contactor. The benefits of this design include compact size and reduced installation costs combined with an electrical capacity sufficient for most small and medium size electric vehicles.

Whilst the switches are primarily intended for use with battery powered vehicles, they are also suitable for use with static power systems. All types are capable of safely rupturing full load battery currents in the event of an emergency.

Optionally, a fuseholder for an inline fuse can be provided pre-fitted. This modification adjusts the positions of the coil terminals and is suitable for ANL or MEGA fuse configurations.



SD300A

Modes of Operation:

Knob depressed
Coil de-energised
Main contacts open
N.O. auxiliary contacts open

1...

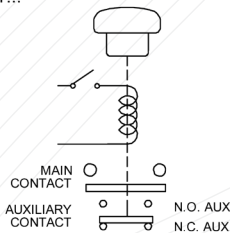

Knob in "ON" position
Coil de-energised
Main contacts open
N.O. auxiliary contacts closed

2...

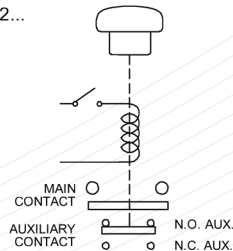

Knob in "ON" position
Coil energised
Main contacts closed
N.O. auxiliary contacts closed

3...

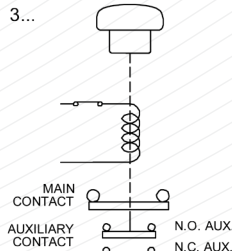

The operation of the switch is such that with the operating knob depressed i.e. in the "off" position, no electrical functions can take place. However, if the knob is in the "On" position, the option of energising the coil and thus closing the main contacts becomes available. The coil energisation can be carried out either through the vehicle keyswitch or as a result of a signal from the vehicle electronic controller. When used as an emergency battery disconnect switch, manually depressing the operating knob will override the energised coil such that the main contact and the auxiliary contact (where fitted) will open until such time as the knob is again moved to the "on" position.

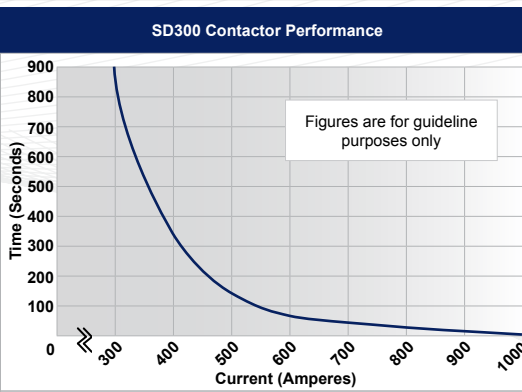

Contact Performance Key: — Uninterrupted Current

- Performance data provided should be used as a guide only. Some de-rating or variation from figures may be necessary according to application.
- Thermal current ratings stated are dependant upon the size of conductor being used
- For further technical advice email: technical@albrightinternational.com
- Albright reserve the right to change data without prior notice

SD300 Available Options		
General		Suffix
Auxiliary Contacts	○	A
Auxiliary Contacts - V3	X	
Magnetic Blowouts†	○	B
Magnetic Blowouts - High Powered†	○	B
Armature Cap‡	●	
Mounting Brackets	X	
Magnetic Latching† (Not fail safe)	X	
Closed Contact Housing	○	
Environmentally Protected IP55	X	
EE Type (Steel Shroud)	X	
Lockable	X	
Contacts		
Large Tips	X	
Textured Tips	○	T
Silver Plating	X	
Coil		
AC Rectifier Board (Fitted)‡	○	
Coil Suppression†	○	
Flying Leads‡	○	F
Manual Override Operation	●	
M4 Stud Terminals	X	
M5 Terminal Board‡	○	
Vacuum Impregnation‡	○	
Key: Optional ○ Standard ● Not Available X		
† Connections become polarity sensitive		
‡ Fuseholder type only		

The Use of Battery Disconnecting Switches in Electric Vehicles

Modern battery powered electric vehicles are inherently very reliable and safe. However, even when sophisticated electronic controllers are used it is desirable to have a means of disconnecting the battery in the event of an emergency, such as a vehicle failing to stop or an electrical short circuit.

In many countries it is mandatory to fit one or more devices to achieve an emergency disconnection of the battery.

SD300A Drawing

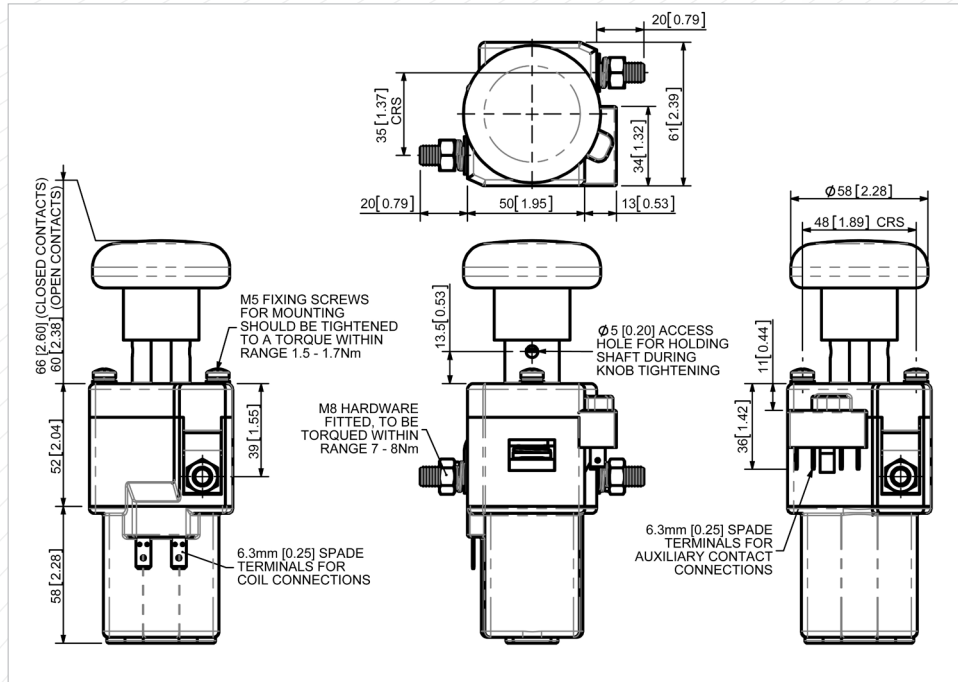

SD300A

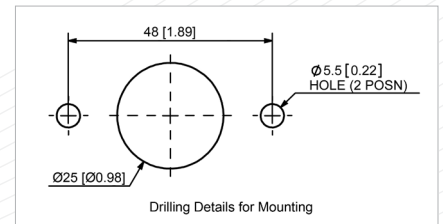

Drilling Details for Mounting

SD300A Fuseholder Drawing

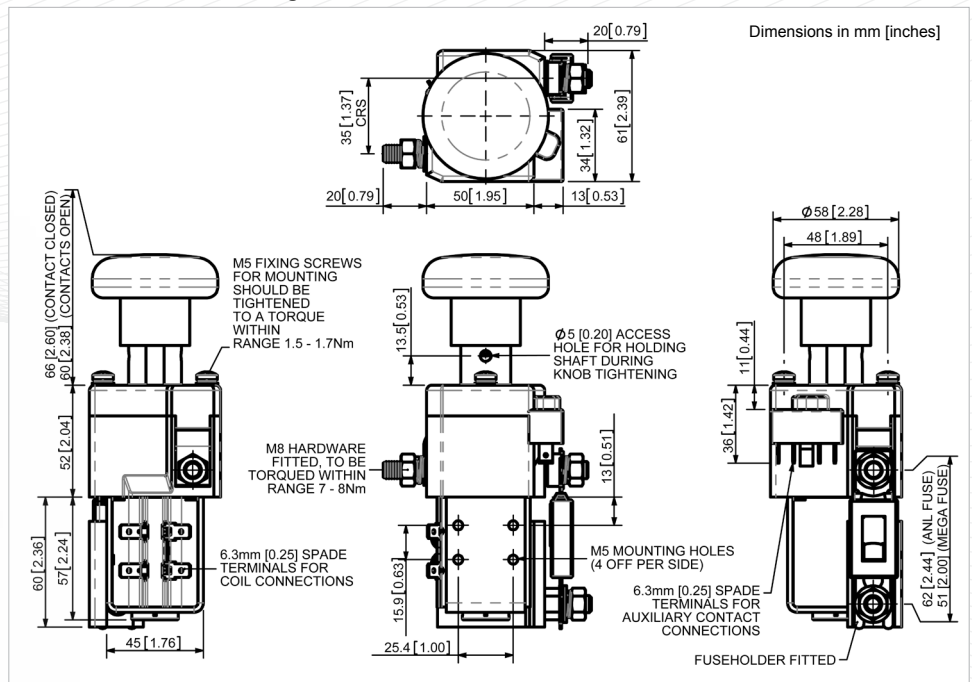

Dimensions in mm [inches]

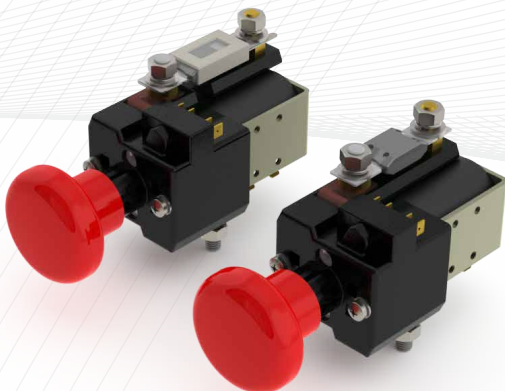

SD300A Fuseholder

Precautions:

When fitted with magnetic blowouts the polarity marked on the contact housing must be observed when connecting the main terminals. Ensure that the switches are installed in a position where heavy arcs emanating from the switch cannot damage or electrically jump across to adjacent parts.

The switch is to be used to rupture current in an emergency or as a no-load isolator. **Do not use as a regular On-Load Switching Device.**