

Архангельск (8182)63-90-72 Астана (7172)727-132 Астрахань (8512)99-46-04 Барнаул (3852)73-04-60 Белгород (4722)40-23-64 Брянск (4832)59-03-52 Владивосток (423)249-28-31 Волгоград (844)278-03-48 Вологда (8172)26-41-59 Воронеж (473)204-51-73 Екатеринбург (343)384-55-89 Иваново (4932)77-34-06 Ижевск (3412)26-03-58 Казань (843)206-01-48 Калининград (4012)72-03-81 Калуга (4842)92-23-67 Кемерово (3842)65-04-62 Киров (8332)68-02-04 Краснодар (861)203-40-90 Красноярск (391)204-63-61 Курск (4712)77-13-04 Липецк (4742)52-20-81 Магнитогорск (3519)55-03-13 Москва (495)268-04-70 Мурманск (8152)59-64-93 Набережные Челны (8552)20-53-41 Нижний Новгород (831)429-08-12 Новокузнецк (3843)20-46-81 Новосибирск (383)227-86-73 Омск (3812)21-46-40 Орел (4862)44-53-42 Оренбург (3532)37-68-04 Пенза (8412)22-31-16 Пермь (342)205-81-47 Ростов-на-Дону (863)308-18-15 Рязань (4912)46-61-64 Самара (846)206-03-16 Санкт-Петербург (812)309-46-40 Саратов (845)249-38-78 Севастополь (8692)22-31-93 Симферополь (3652)67-13-56 Смоленск (4812)29-41-54 Сочи (862)225-72-31 Ставрополь (8652)20-65-13 Сургут (3462)77-98-35 Тверь (4822)63-31-35 Томск (3822)98-41-53 Тула (4872)74-02-29 Тюмень (3452)66-21-18 Ульяновск (8422)24-23-59 Уфа (347)229-48-12 Хабаровск (4212)92-98-04 Челябинск (351)202-03-61 Череповец (8202)49-02-64 Ярославль (4852)69-52-93

Единый адрес: ath@nt-rt.ru | <http://albright.nt-rt.ru>

| Application | Uninterrupted |
|---|---|
| Thermal Current Rating (I_{th}) | 125A |
| Intermittent Current Rating: | |
| 30% Duty | 230A |
| 40% Duty | 200A |
| 50% Duty | 175A |
| 60% Duty | 160A |
| 70% Duty | 150A |
| Rated Fault Current Breaking Capacity (I_{cn}) 5ms Time Constant: (in accordance with UL583*) | |
| RW80 | 800A at 48V |
| RW80B | 800A at 80V |
| Rated Fault Current Breaking Capacity (I_{cn}) Resistive Load: (in accordance with UL508*) | |
| RW80 | 190A at 60V D.C. |
| RW80B | 190A at 96V D.C. |
| Maximum Recommended Contact Voltages (U_{0}): | |
| RW80 | 60V D.C. |
| RW80B | 96V D.C. |
| Typical Voltage Drop per pole across New Contacts at 125A | 40mV |
| Mechanical M.T.B.F | >5 x 10 ⁶ |
| Coil Voltage Available (U_s) (Rectifier board required for A.C.) | From 6 to 240V D.C. |
| Coil Power Dissipation: | |
| Highly Intermittent Rated Types | 20 - 30 Watts |
| Intermittently Rated types | 15 - 20 Watts |
| Prolonged Rated Types | 13 - 15 Watts |
| Continuously Rated Types | 7 - 13 Watts |
| Maximum Pull-In Voltage (Coil at 20° C) Guideline: | |
| Highly Intermittent Rated types (Max 25% Duty Cycle) | 60% U_s |
| Intermittently Rated types (Max 70% Duty Cycle) | 60% U_s |
| Prolonged Operation (Max 90% Duty Cycle) | 60% U_s |
| Continuously Rated Types (100% Duty Cycle) | 66% U_s |
| Drop-Out Voltage Range | 10 - 25% U_s |
| Typical Pull-In Time | 20ms |
| Typical Drop-Out Time (N/O Contacts to Open): | |
| Without Suppression | 5ms |
| With Diode Suppression | 50ms |
| With Diode and Resistor (Subject to resistance value) | 8 - 20ms |
| Typical Contact Bounce Period | 3ms |
| Operating Ambient Temperature | -40°C to +60°C |
| Guideline Contactor Weight: | |
| RW80 | 350 gms |
| With Auxiliary | + 20 gms |
| With Blowouts | + 50 gms |
| Auxiliary Thermal Current Rating | 5A |
| Auxiliary Contact Switching Capabilities (Resistive Load): | |
| RW80C | RW80A |
| 5A at 24V D.C. | |
| 2A at 48V D.C. | |
| 0.5A at 240V D.C. | |
| Advised Connection Sizes for Maximum Continuous Current | |
| Copper busbar | 80mm ² [0.124inch ²] |
| Cable | Rated suitable for Application |
| Key: ▲ = Uninterrupted | |
| Note: Where applicable values shown are at 20° C | |
| * Please check our web site for product UL status | |

The Reduced Silver series are suitable for applications where infrequent switching is specified. In such applications the degradation of the tip is minimal and therefore a higher volume of silver is unnecessary. Developed for Uninterrupted current applications the RW80 is typically used in line contactors and Power Distribution Systems.

- Uninterrupted current - no or infrequent load switching requirements (maintains a lower contact resistance).

The RW80 features single pole double breaking main contacts with silver alloy tips, which are weld resistant, hard wearing and have excellent conductivity. The RW80 has M8 stud main terminals and 6.3mm spade coil connections. Mounting is via M4 tapped holes or mounting brackets, either supplied fitted, or as separate items. Mounting can be horizontal or vertical, when vertical the M8 contact studs should point upwards. If the requirement is for downwards orientation we can adjust the contactor to compensate for this.

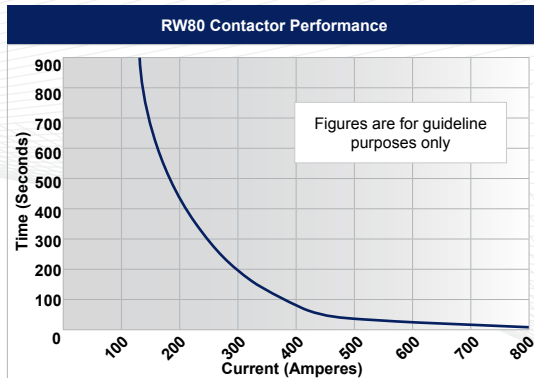
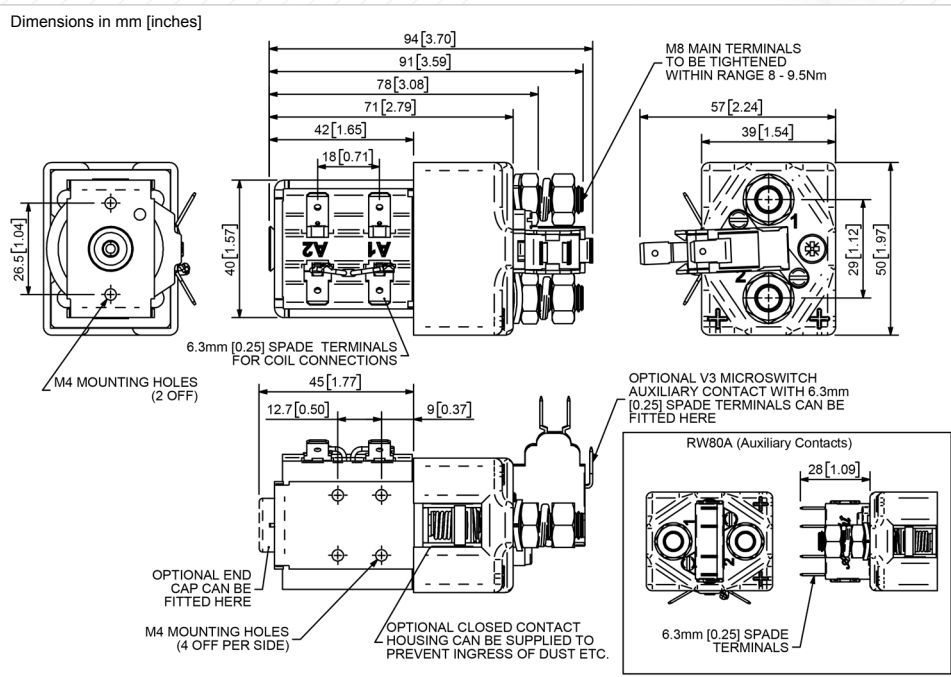
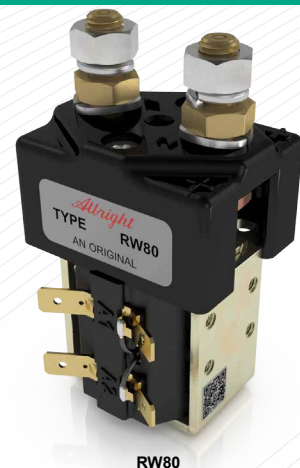

Contact Performance Key:

— Uninterrupted Current

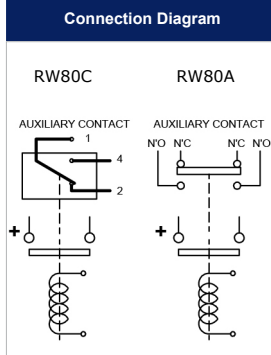

| RW80 Available Options | | |
|--|---|--------|
| General | | Suffix |
| Auxiliary Contacts | ○ | A |
| Auxiliary Contacts - V3 | ○ | C |
| Magnetic Blowouts† | ○ | B |
| Magnetic Blowouts - High Powered† | ○ | B |
| Armature Cap | ○ | |
| Mounting Brackets (See Stud Series Catalogue) | ○ | |
| Magnetic Latching† (Not fail safe) | ○ | M |
| Closed Contact Housing‡ | ○ | |
| Environmentally Protected IP66 (see RU80P Catalogue sheet) | ○ | P |
| EE Type (Steel Shroud) | ○ | EE |
| Contacts | | |
| Textured Tips | ○ | T |
| Silver Plating | X | |
| Coil | | |
| AC Rectifier Board (Fitted) | ○ | |
| Coil Suppression† | ○ | |
| Flying Leads | ○ | F |
| Manual Override Operation | ○ | |
| M4 Stud Terminals | X | |
| M5 Terminal Board | ○ | |
| Vacuum Impregnation | ○ | |
| Key: Optional ○ Standard ● Not Available X | | |
| † Connections become polarity sensitive | | |
| ‡ Open Housing Available | | |