

Архангельск (8182)63-90-72 Астана (7172)727-132 Астрахань (8512)99-46-04 Барнаул (3852)73-04-60 Белгород (4722)40-23-64 Брянск (4832)59-03-52 Владивосток (423)249-28-31 Волгоград (844)278-03-48 Вологда (8172)26-41-59 Воронеж (473)204-51-73 Екатеринбург (343)384-55-89 Иваново (4932)77-34-06 Ижевск (3412)26-03-58 Казань (843)206-01-48 Калининград (4012)72-03-81 Калуга (4842)92-23-67 Кемерово (3842)65-04-62 Киров (8332)68-02-04 Краснодар (861)203-40-90 Красноярск (391)204-63-61 Курск (4712)77-13-04 Липецк (4742)52-20-81 Магнитогорск (3519)55-03-13 Москва (495)268-04-70 Мурманск (8152)59-64-93 Набережные Челны (8552)20-53-41 Нижний Новгород (831)429-08-12 Новокузнецк (3843)20-46-81 Новосибирск (383)227-86-73 Омск (3812)21-46-40 Орел (4862)44-53-42 Оренбург (3532)37-68-04 Пенза (8412)22-31-16 Пермь (342)205-81-47 Ростов-на-Дону (863)308-18-15 Рязань (4912)46-61-64 Самара (846)206-03-16 Санкт-Петербург (812)309-46-40 Саратов (845)249-38-78 Севастополь (8692)22-31-93 Симферополь (3652)67-13-56 Смоленск (4812)29-41-54 Сочи (862)225-72-31 Ставрополь (8652)20-65-13 Сургут (3462)77-98-35 Тверь (4822)63-31-35 Томск (3822)98-41-53 Тула (4872)74-02-29 Тюмень (3452)66-21-18 Ульяновск (8422)24-23-59 Уфа (347)229-48-12 Хабаровск (4212)92-98-04 Челябинск (351)202-03-61 Череповец (8202)49-02-64 Ярославль (4852)69-52-93

Единый адрес: ath@nt-rt.ru | http://albright.nt-rt.ru

The Reduced Silver series are suitable for applications where infrequent switching is specified. In such applications the degradation of the tip is minimal and therefore a higher volume of silver is unnecessary. The RW300 is designed for use in telecommunication and power distribution applications where an uninterrupted load is switched. These contactors are primarily for use with Direct Current loads but can also be used with Alternating Currents.

| Application | Uninterrupted |
|--|---|
| Thermal Current Rating (I_{th}) | 300A |
| Intermittent Current Rating: | |
| 30% Duty | 550A |
| 40% Duty | 475A |
| 50% Duty | 425A |
| 60% Duty | 390A |
| 70% Duty | 360A |
| Rated Fault Current Breaking Capacity (I_{cn}) Resistive Load: (in accordance with UL508*) | |
| RW300 | 450A at 60V D.C. |
| Maximum Recommended Contact Voltages (U_{θ}): | |
| RW300 | 60V D.C. |
| Typical Voltage Drop per pole across New Contacts at 300A | < 50mV |
| Mechanical M.T.B.F | > 1 x 10 ⁶ |
| Coil Voltage Available (U_s) (Rectifier board required for A.C.) | From 6 to 240V A.C./D.C. |
| Coil Power Dissipation: | |
| Highly Intermittent Rated Types | 20 - 30 Watts |
| Intermittently Rated Types | 15 - 20 Watts |
| Prolonged Rated Types | 13 - 15 Watts |
| Continuously Rated Types | 7 - 13 Watts |
| Maximum Pull-In Voltage (Coil at 20° C) Guideline: | |
| Highly Intermittent Rated types (Max 25% Duty Cycle) | 60% U_s |
| Intermittently Rated types (Max 70% Duty Cycle) | 60% U_s |
| Prolonged Operation (Max 90% Duty Cycle) | 60% U_s |
| Continuously Rated Types (100% Duty Cycle) | 66% U_s |
| Drop-Out Voltage Range | 10 - 30% U_s |
| Typical Pull-In Time | 15ms |
| Typical Drop-Out Time (N/O Contacts to Open): | |
| Without Suppression | 6ms |
| With Diode Suppression | 35ms |
| With Diode and Resistor (Subject to resistance value) | 20ms |
| Typical Contact Bounce Period | < 5ms |
| Operating Ambient Temperature | - 40°C to + 60°C |
| Guideline Contactor Weight: | |
| RW300 | 560 gms |
| With Auxiliary | + 20 gms |
| Auxiliary Details | |
| Auxiliary Thermal Current Rating | 5A |
| Auxiliary Contact Switching Capabilities (Resistive Load): | |
| RW300A | RW300C |
| | 5A at 24V D.C. |
| | 2A at 48V D.C. |
| | 1.3A at 72V D.C. |
| Advised Connection Sizes for Maximum Continuous Current | |
| Copper busbar | 194mm ² [0.30inch ²] |
| Cable | Rated Suitable for Application |
| Key: ▲ Uninterrupted | |
| Note: Where applicable values shown are at 20°C | |
| * Please check our web site for product UL status | |

- **Uninterrupted current** - no or infrequent load switching requirements (maintains a lower contact resistance).

The RW300 features double breaking main contacts with silver alloy tips which are weld resistant, hard wearing and have excellent conductivity. Silver plating on the main contacts is optional for the RW300. The RW300 is a compact contactor which can be busbar mounted vertically or horizontally, if mounted vertically the coil should be at the bottom. If the coil is required at the top, we can adjust the contactor to compensate for this.

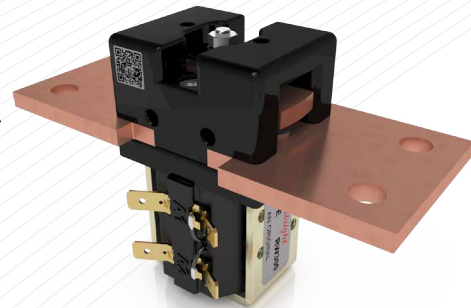

RW300

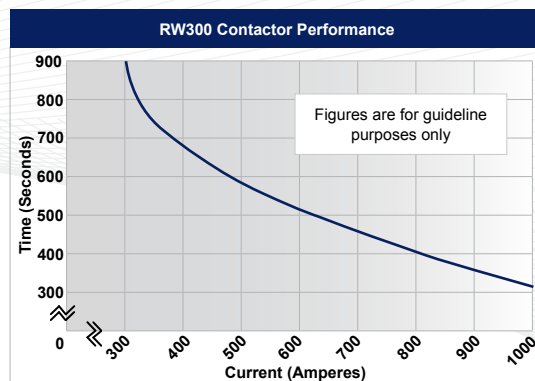
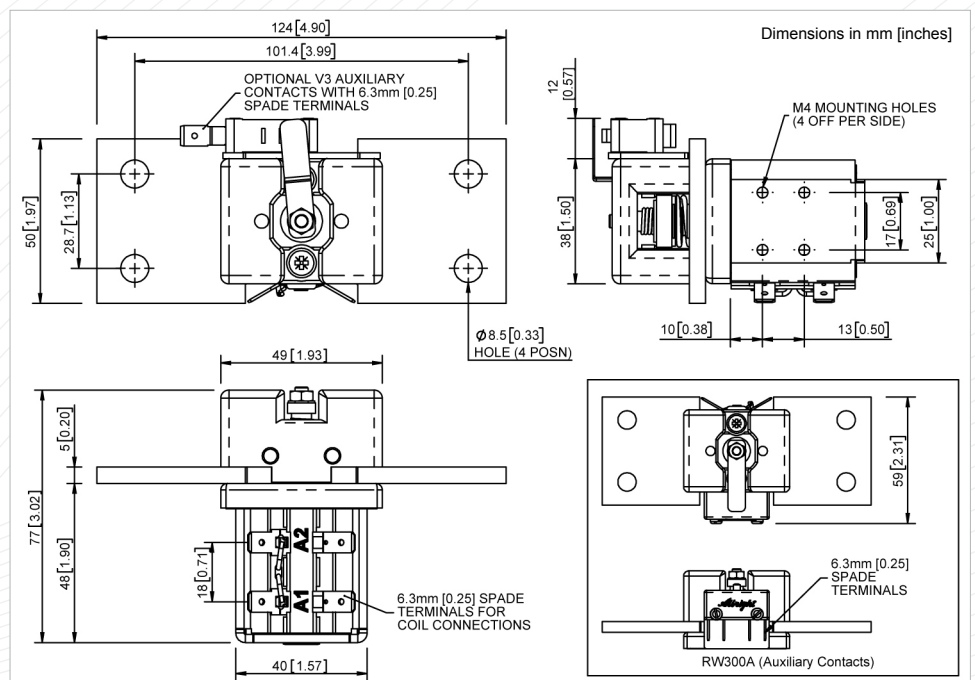

Contact Performance Key:

— Uninterrupted Current

Connection Diagram

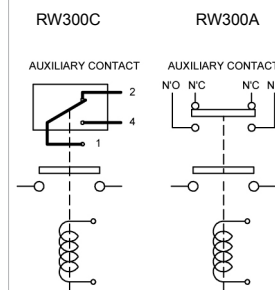

RW300 Available Options

| General | Suffix | |
|---|----------|----------|
| | Standard | Optional |
| Auxiliary Contacts | ○ | A |
| Auxiliary Contacts - V3 | ○ | C |
| Magnetic Blowouts† | × | |
| Magnetic Blowouts - High Powered† | × | |
| Armature Cap | × | |
| Mounting Brackets (see Busbar Series Catalogue) | ○ | |
| Magnetic Latching† (Not fail safe) | ○ | M |
| Closed Contact Housing | × | |
| Environmentally Protected IP66 | × | |
| EE Type (Steel Shroud) | × | |
| Contacts | | |
| Textured Tips | ○ | T |
| Silver Plating | ○ | |
| Coil | | |
| AC Rectifier Board (Fitted) | ○ | |
| Coil Suppression† | ○ | |
| Flying Leads | ○ | F |
| Manual Override Operation | ○ | |
| M4 Stud Terminals | × | |
| M5 Terminal Board | ○ | |
| Vacuum Impregnation | ○ | |
| Key: Optional ○ Standard ● Not Available X | | |
| † Connections become polarity sensitive | | |