

Архангельск (8182)63-90-72 Астана (7172)727-132 Астрахань (8512)99-46-04 Барнаул (3852)73-04-60 Белгород (4722)40-23-64 Брянск (4832)59-03-52 Владивосток (423)249-28-31 Волгоград (844)278-03-48 Вологда (8172)26-41-59 Воронеж (473)204-51-73 Екатеринбург (343)384-55-89 Иваново (4932)77-34-06 Ижевск (3412)26-03-58 Казань (843)206-01-48 Калининград (4012)72-03-81 Калуга (4842)92-23-67 Кемерово (3842)65-04-62 Киров (8332)68-02-04 Краснодар (861)203-40-90 Красноярск (391)204-63-61 Курск (4712)77-13-04 Липецк (4742)52-20-81 Магнитогорск (3519)55-03-13 Москва (495)268-04-70 Мурманск (8152)59-64-93 Набережные Челны (8552)20-53-41 Нижний Новгород (831)429-08-12 Новокузнецк (3843)20-46-81 Новосибирск (383)227-86-73 Омск (3812)21-46-40 Орел (4862)44-53-42 Оренбург (3532)37-68-04 Пенза (8412)22-31-16 Пермь (342)205-81-47 Ростов-на-Дону (863)308-18-15 Рязань (4912)46-61-64 Самара (846)206-03-16 Санкт-Петербург (812)309-46-40 Саратов (845)249-38-78 Севастополь (8692)22-31-93 Симферополь (3652)67-13-56 Смоленск (4812)29-41-54 Сочи (862)225-72-31 Ставрополь (8652)20-65-13 Сургут (3462)77-98-35 Тверь (4822)63-31-35 Томск (3822)98-41-53 Тула (4872)74-02-29 Тюмень (3452)66-21-18 Ульяновск (8422)24-23-59 Уфа (347)229-48-12 Хабаровск (4212)92-98-04 Челябинск (351)202-03-61 Череповец (8202)49-02-64 Ярославль (4852)69-52-93

Единый адрес: ath@nt-rt.ru | <http://albright.nt-rt.ru>

The Reduced Silver series are suitable for applications where infrequent switching is specified. In such applications the degradation of the tip is minimal and therefore a higher volume of silver is unnecessary. The RW250 is designed for use in telecommunications and power distribution applications where an uninterrupted load is switched. These contactors are primarily for use with Direct Current loads but can also be used with Alternating Currents.

Application	Uninterrupted
Thermal Current Rating (I_{th})	250A
Intermittent Current Rating:	
30% Duty	455A
40% Duty	395A
50% Duty	355A
60% Duty	325A
70% Duty	300A
Rated Fault Current Breaking Capacity (I_{cn}) Resistive Load: (in accordance with UL508*)	
RW250	375A at 60V D.C.

Maximum Recommended Contact Voltages (U_0):	
RW250	60V D.C.
Typical Voltage Drop per pole across New Contacts at 250A	< 50mV
Mechanical M.T.B.F	>1 x 10 ⁶
Coil Voltage Available (U_s) (Rectifier board required for A.C.)	From 6 to 240V A.C./D.C.

Coil Power Dissipation:	
Highly Intermittent Rated Types	20 - 30 Watts
Intermittently Rated Types	15 - 20 Watts
Prolonged Rated Types	13 - 15 Watts
Continuously Rated Types	7 - 13 Watts

Maximum Pull-In Voltage (Coil at 20° C) Guideline:

Highly Intermittent Rated types (Max 25% Duty Cycle)	60% U_s
Intermittently Rated types (Max 70% Duty Cycle)	60% U_s
Prolonged Operation (Max 90% Duty Cycle)	60% U_s
Continuously Rated Types (100% Duty Cycle)	66% U_s

Drop-Out Voltage Range	10 - 30% U_s
Typical Pull-In Time	15ms

Typical Drop-Out Time (N/O Contacts to Open):

Without Suppression	6ms
With Diode Suppression	35ms
With Diode and Resistor (Subject to resistance value)	5 - 20ms

Typical Contact Bounce Period	< 5ms
-------------------------------	-------

Operating Ambient Temperature	- 40°C to + 60°C
-------------------------------	------------------

Guideline Contactor Weight:

RW250	470 gms
With Auxiliary	+ 20 gms

Auxiliary Details

Auxiliary Thermal Current Rating	5A
----------------------------------	----

Auxiliary Contact Switching Capabilities (Resistive Load):

RW250C	RW250A
5A at 24V D.C.	
2A at 48V D.C.	
0.5A at 240V D.C.	

Advised Connection Sizes for Maximum Continuous Current

Copper busbar	190mm ² [0.25inch ²]
Cable	Rated suitable for Application

Key: = Uninterrupted

Note: Where applicable values shown are at 20° C

* Please check our web site for product UL status

- Uninterrupted current - no or infrequent load switching requirements (maintains a lower contact resistance).

The RW250 features double breaking main contacts with silver alloy tips which are weld resistant, hard wearing and have excellent conductivity. Silver plating on the main contacts is optional for the RW250. The RW250 is a compact contactor which can be busbar mounted vertically or horizontally, if mounted vertically the coil should be at the bottom. If the coil is required at the top, we can adjust the contactor to compensate for this.

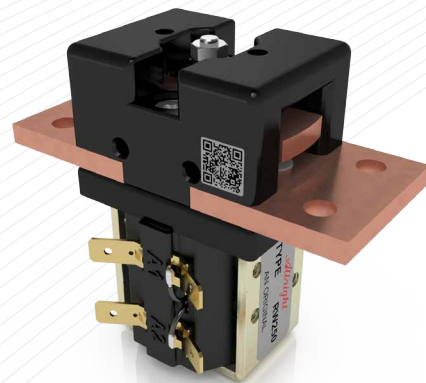

RW250

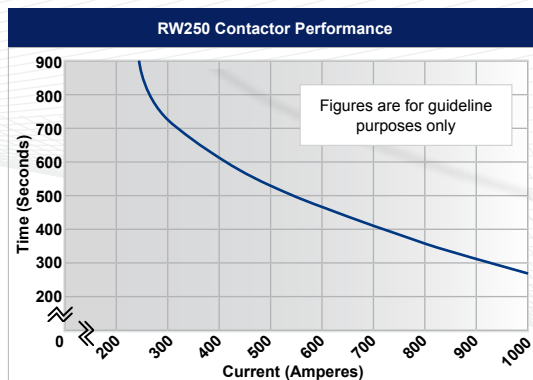
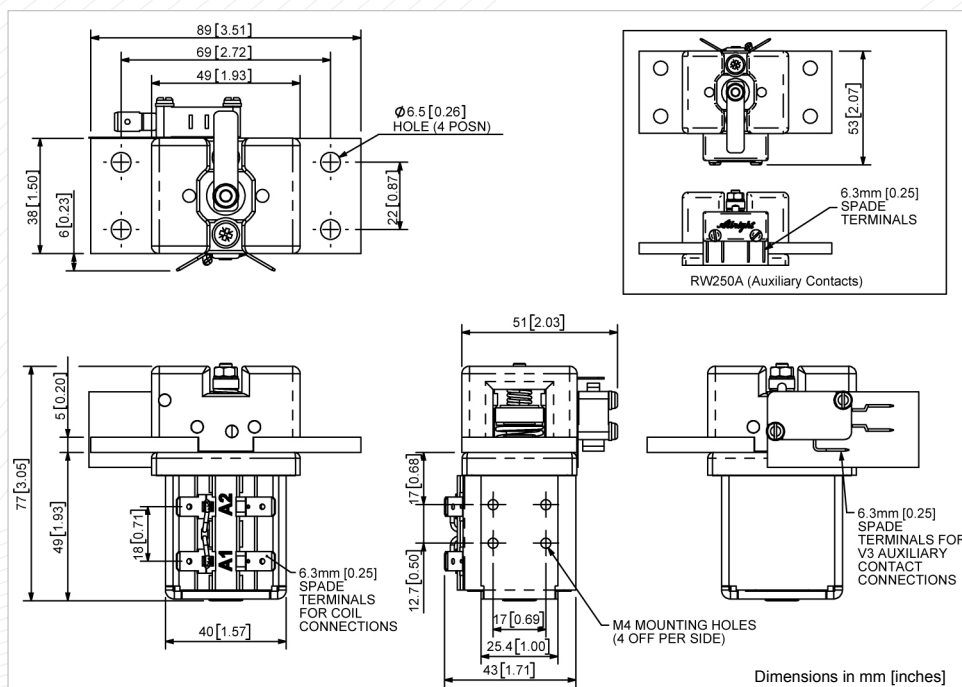

Contact Performance Key:

— Uninterrupted Current

Connection Diagram

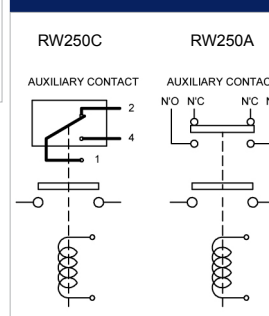

RW250 Available Options

General		Suffix
Auxiliary Contacts	<input type="radio"/>	A
Auxiliary Contacts - V3	<input type="radio"/>	C
Magnetic Blowouts†	<input checked="" type="checkbox"/>	X
Magnetic Blowouts - High Powered†	<input checked="" type="checkbox"/>	X
Armature Cap	<input checked="" type="checkbox"/>	X
Mounting Brackets (see Busbar Series Catalogue)	<input type="radio"/>	
Magnetic Latching† (Not fail safe)	<input type="radio"/>	M
Closed Contact Housing	<input checked="" type="checkbox"/>	X
Environmentally Protected IP66	<input checked="" type="checkbox"/>	X
EE Type (Steel Shroud)	<input checked="" type="checkbox"/>	X
Contacts		
Textured Tips	<input type="radio"/>	T
Silver Plating	<input type="radio"/>	
Coil		
AC Rectifier Board (Fitted)	<input type="radio"/>	
Coil Suppression†	<input type="radio"/>	
Flying Leads	<input type="radio"/>	F
Manual Override Operation	<input type="radio"/>	
M4 Stud Terminals	<input checked="" type="checkbox"/>	X
M5 Terminal Board	<input type="radio"/>	
Vacuum Impregnation	<input type="radio"/>	
Key: Optional <input type="radio"/> Standard <input checked="" type="checkbox"/> Not Available <input checked="" type="checkbox"/>		
† Connections become polarity sensitive		